

# IN.05.213 / IN.05.213.HO / IN.05.213.BH1 / IN.05.213.BH1



**SISTEMA PIVOTANTE HIDRÁULICO 100 PLUS**  
HYDRAULIC PIVOTING SYSTEM 100 PLUS  
SISTEMA HIDRÁULICO DE PIVOTE 100 PLUS



## Conteúdo / Content / Contenido

Ferramenta necessária / Necessary tools / Herramienta necesaria	2
Dimensão da porta / Door dimension / Dimensión de la puerta	3
Desenho técnico / Technical drawing / Diseño técnico	4
Entalhe / Cutout / Taladro	6
Esquema de perfuração / Drilling scheme / Esquema de perforación	8
Instalação / Installation / Instalación	9
Ajustes de posição / Position adjustment / Ajuste de posición	17
Ajuste de velocidade / Speed adjustment / Ajuste de velocidad	18
Manutenção / Maintenance / Mantenimiento	19

## Ferramentas necessárias (Não incluídas) /

Tools required (Not included) / Herramientas necesarias (No incluidas)

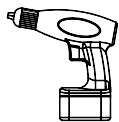

**Berbequim /**  
Driller /  
Taladrador



**Nível laser /**  
Laser level/  
Nivel láser



**Chave Philips /**  
Philips Screwdriver /  
Destornillador Philips

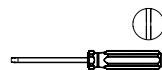

**Chave fenda /**  
Screwdriver /  
Destornillador

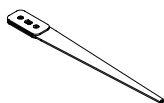

**IN.05.ST**  
Chave especial/  
Special key/  
Llave especial

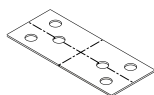

**IN.05.215.50 (opcional)**  
Ferramenta Furação /  
Drill tool /  
Herramienta de perforación

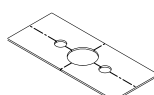

**IN.05.215.51 (opcional)**  
Ferramenta Furação /  
Drill tool /  
Herramienta de perforación

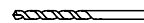

**Broca Ø12mm /**  
Drill bit Ø12mm /  
Broca Ø12mm

## Ferramentas incluídas / Tools included / Herramientas incluidas - KIT STANDARD

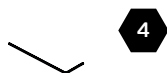

**IN.05.213.5**  
Chave especial /  
Special key/  
Llave especial

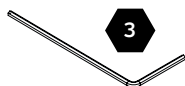

**Chave Allen 3mm /**  
Allen key 3mm /  
Llave Allen 3mm



**Chave Allen 5mm /**  
Allen key 5mm /  
Llave Allen 5mm

**Dimensão da porta / Door dimension / Dimensión de la puerta**

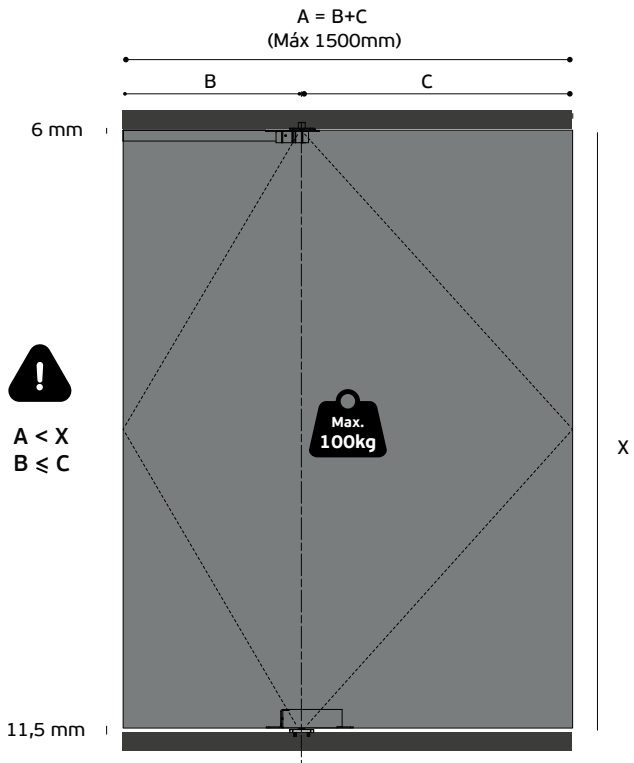

**Dimensão da porta /**  
Door dimension /  
Dimensión de la puerta

A(max)	B(mín)	C(max)
1120	120	1000
1320	220	1120
1500	265	1235

**Tabela de folgas / Clearance Table / Tabla de holgura**



B'		
B \ T (min)	40	50
150	3	4
250	3	3
500	2	3
1000	2	2
1500	2	2

C'		
C \ T (min)	40	50
150	3	4
250	3	3
500	2	3
1000	2	2
1500	2	2

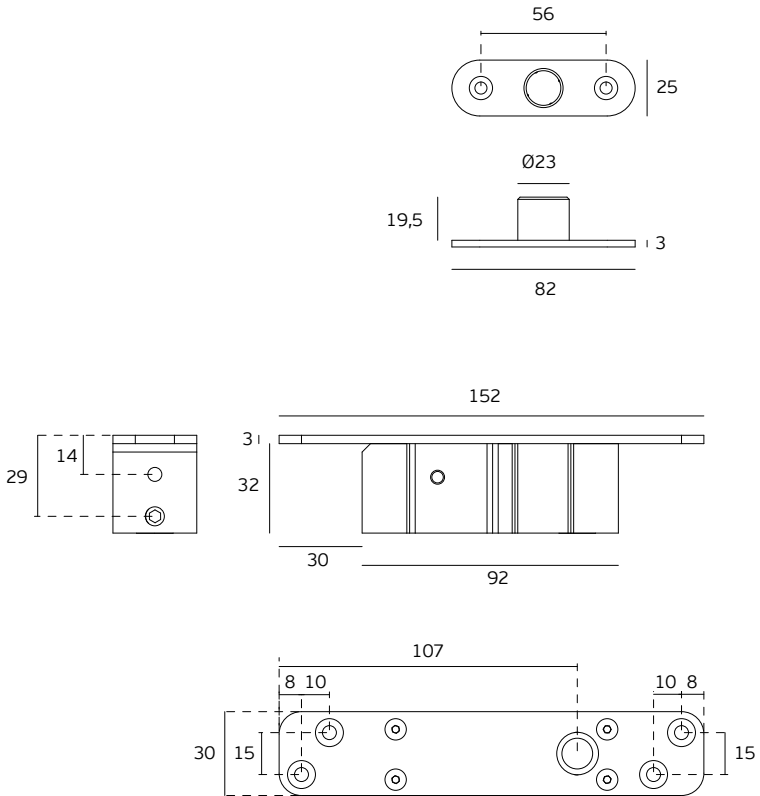

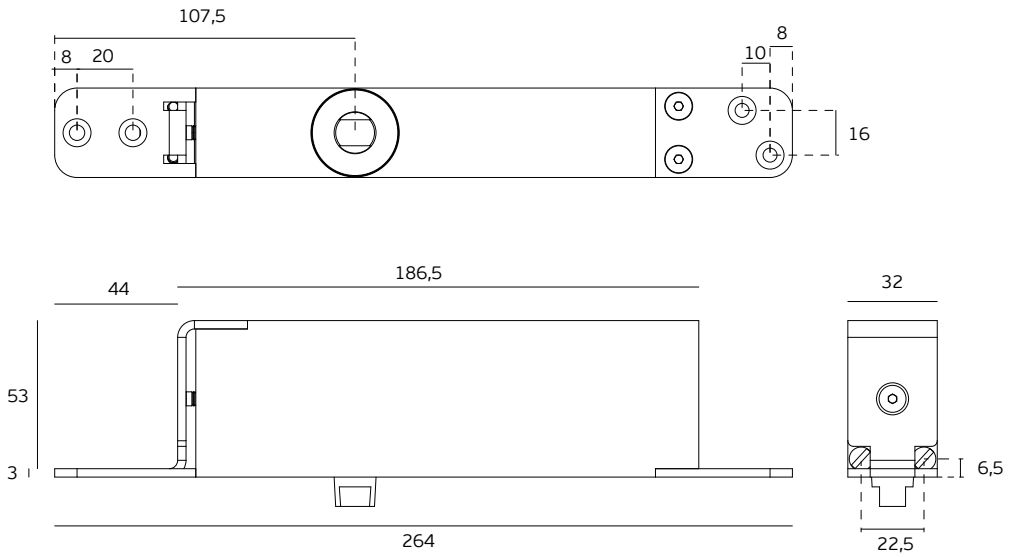

**BH3** - STANDARD

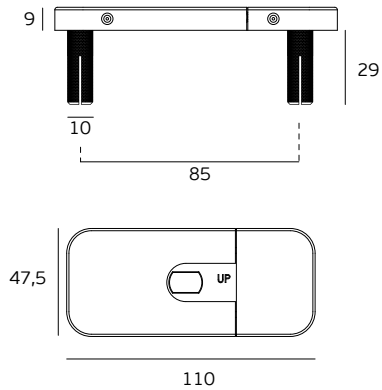

**BH1**

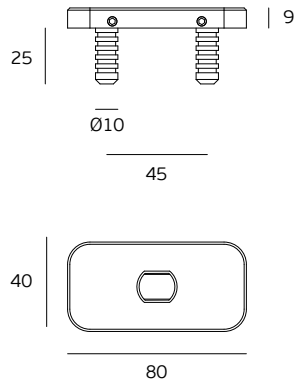

Superior (Aro) /  
Top (Rim) /  
Superior (Aro)

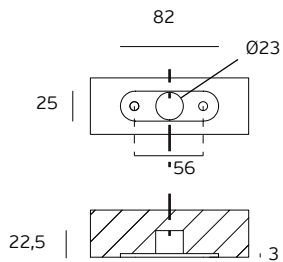

**Rasgo de 8mm até ao exterior da porta /**  
8mm slot to the exterior of the door /  
Taladro de 8mm al exterior de la puerta

Superior (Porta) /  
Top (Door) /  
Superior (puerta)

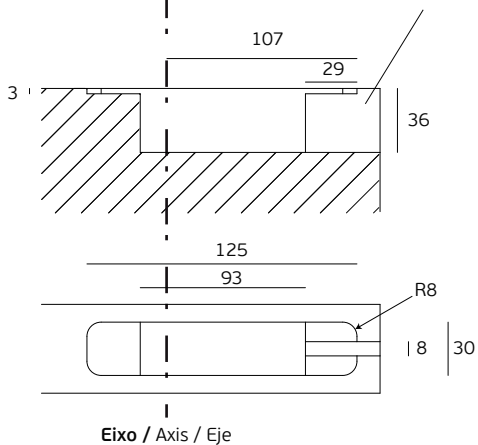

Inferior (Porta) /  
Bottom (Door) /  
Inferior (Puerta)

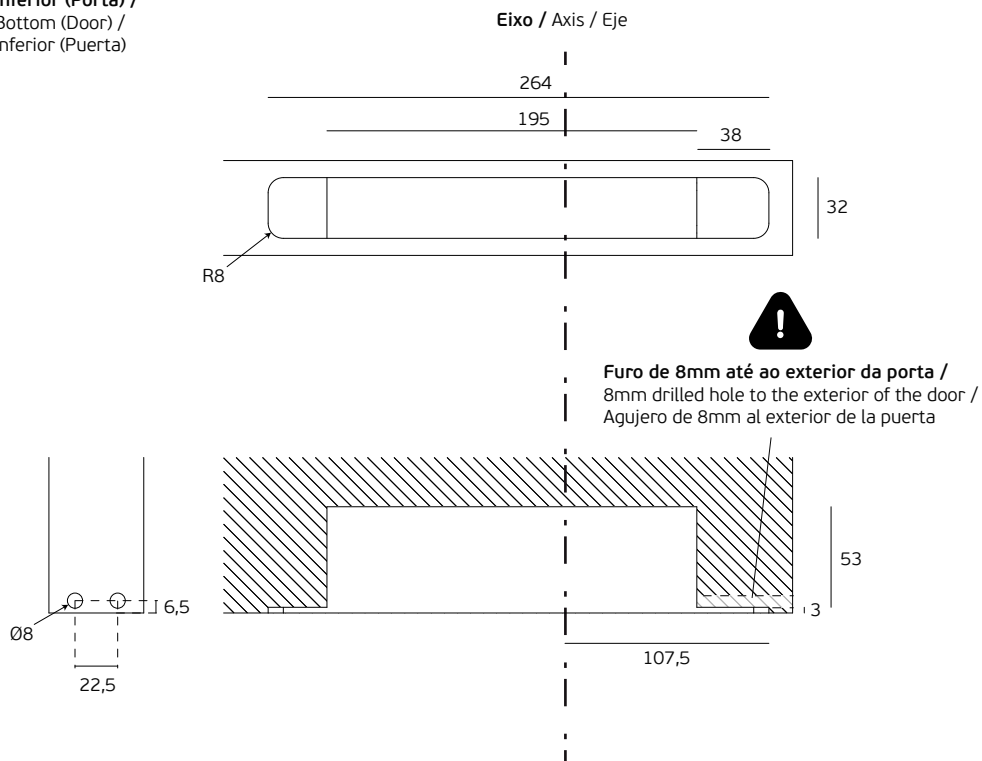

Inferior (Solo) /  
Bottom (Floor) /  
Inferior (Piso)

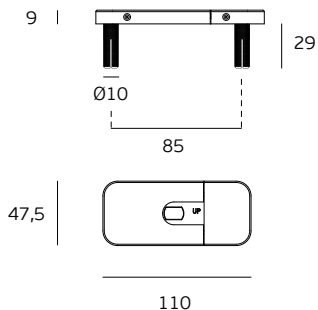

Consultar os anexos /  
See the attachments /  
Consultar los anexos

Utilizar a ferramenta profissional IN.05.215.51 /  
Use the professional tool IN.05.215.51 /  
Utilice la herramienta profesional IN.05.215.51.

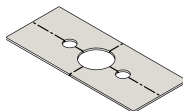

**AVISO - RISCO DE MAU FUNCIONAMENTO!**  
WARNING - RISK OF MALFUNCTION!  
ADVERTENCIA - ¡RIESGO DE MAL FUNCIONAMIENTO!

**OS EIXOS DEVEM ESTAR CENTRADOS.**  
THE AXLES MUST BE CENTERED.  
LOS EJES DEBEN ESTAR CENTRADOS.

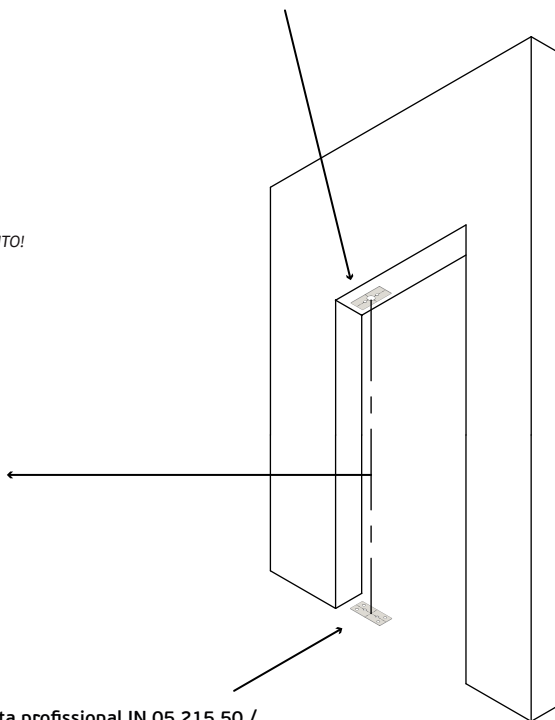
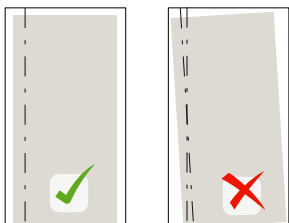

Utilizar a ferramenta profissional IN.05.215.50 /  
Use the professional tool IN.05.215.50 /  
Utilice la herramienta profesional IN.05.215.50.

IN.05.215.50  
(opcional)

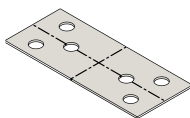

**1 (a)**

**Opção A /  
Option A / Opción A - BH3**

**STANDARD**



**Chão de cimento**  
Concrete floor  
Piso de cemento



**Junta**  
Joint  
Junta

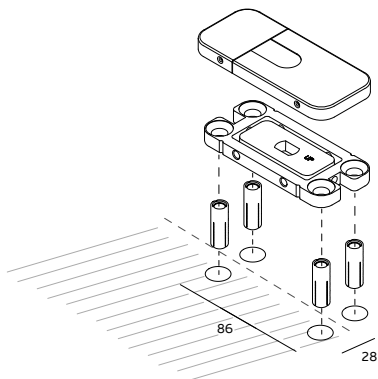

**OBS:**

**Os acessórios de fixação e o sistema de ancoragem (mecânico ou químico) deverão ser escolhidos de acordo com a estrutura, onde irá ser aplicado o produto. Esta escolha, assim como a sua aplicação, deverá ser executada por um profissional.**

Fixing accessories and anchoring system (mechanical or chemical) shall be chosen according to the structure, where the product will be applied. This choice, like your application, should be executed by a professional.

Los accesorios de fijación y el sistema de anclaje (mecánico o químico) deben elegirse según la estructura donde se aplicará el producto. Esta elección, así como su aplicación, debe ser realizada por un profesional.

**1 (b)**

**Opção B /  
Option B / Opción B - BH3**



**Aço**  
Steel  
Acero

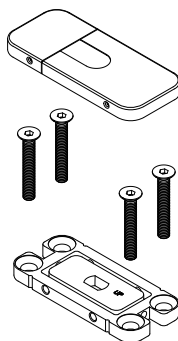

Opção B / Option B / Opción B - BH1

 **Piso radiante**  
Radian floor  
Suelo radiante

  
Deixar fixar/  
Let it fix /  
Dejar pegar

  
2,5

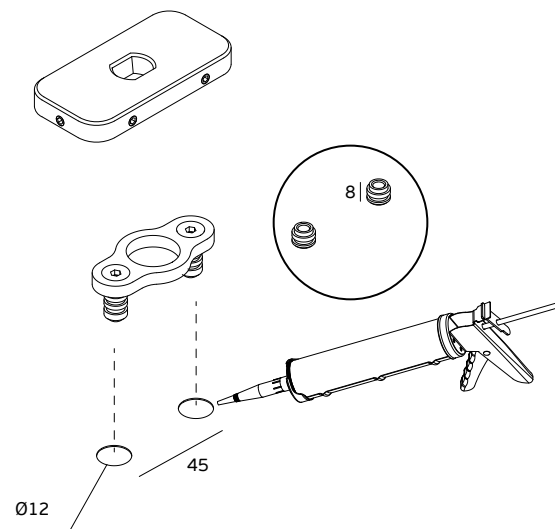

**Seguir tempo de cura  
definido pelo fabricante /  
Follow curing time defined  
by the manufacturer /  
Siga el tiempo de curado  
definido por el fabricante**

**OBS:**

Os acessórios de fixação e o sistema de ancoragem (mecânico ou químico) deverão ser escolhidos de acordo com a estrutura, onde irá ser aplicado o produto. Esta escolha, assim como a sua aplicação, deverá ser executada por um profissional.

Fixing accessories and anchoring system (mechanical or chemical) shall be chosen according to the structure, where the product will be applied. This choice, like its application, should be executed by a professional.

Los accesorios de fijación y el sistema de anclaje (mecánico o químico) deben elegirse según la estructura donde se aplicará el producto. Esta elección, así como su aplicación, debe ser realizada por un profesional.

1(d)

Opção A / Option A / Opción A - BH1



**Chão de cimento**  
Concrete floor  
Piso de cemento



**Deixar fixar /**  
Let it fix /  
Dejar pegar

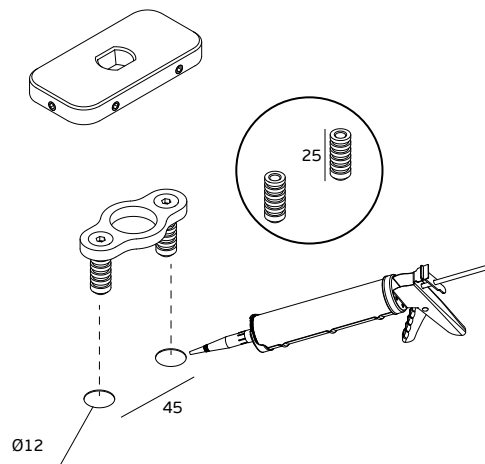

**Seguir tempo de cura**  
definido pelo fabricante /  
Follow curing time defined  
by the manufacturer /  
Siga el tiempo de curado  
definido por el fabricante

**OBS:**

Os acessórios de fixação e o sistema de ancoragem (mecânico ou químico) deverão ser escolhidos de acordo com a estrutura, onde irá ser aplicado o produto. Esta escolha, assim como a sua aplicação, deverá ser executada por um profissional.

Fixing accessories and anchoring system (mechanical or chemical) shall be chosen according to the structure, where the product will be applied. This choice, like its application, should be executed by a professional.

Los accesorios de fijación y el sistema de anclaje (mecánico o químico) deben elegirse según la estructura donde se aplicará el producto. Esta elección, así como su aplicación, debe ser realizada por un profesional.

1(e)

Opção C /  
Option C / Opción C - BH1



**Aço**  
Steel  
Acero

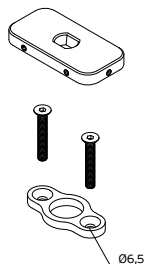

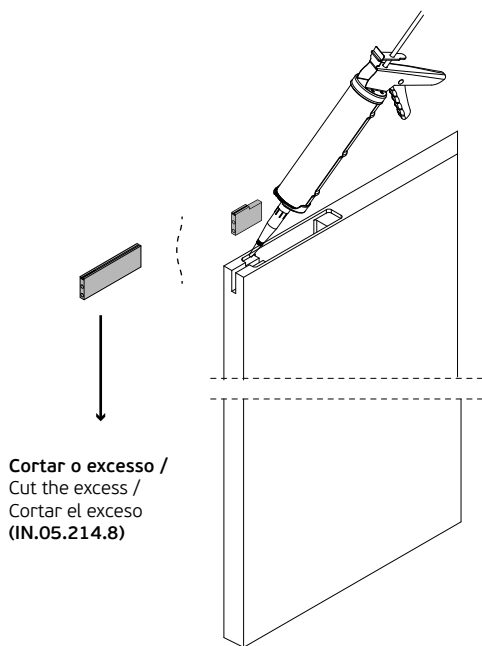
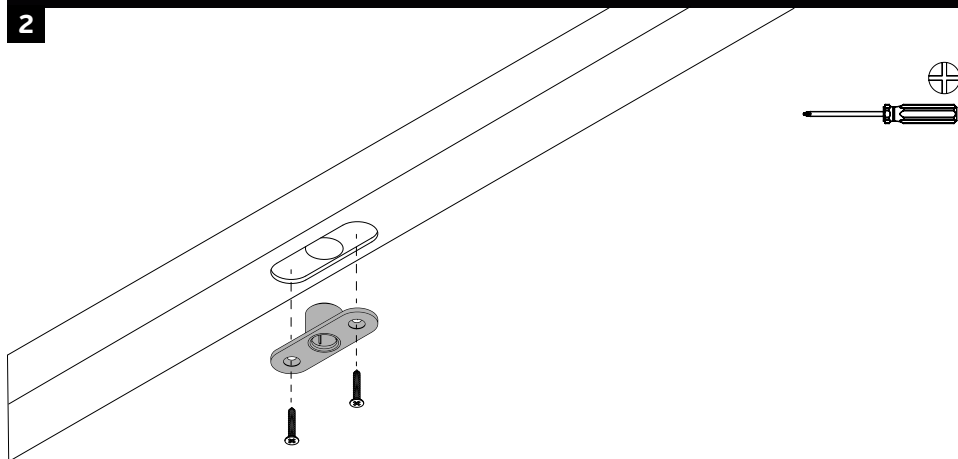

**Cortar o excesso /**  
Cut the excess /  
Cortar el exceso  
(IN.05.214.8)



**Deixar fixar /**  
Let it fix /  
Dejar pegar

**Seguir tempo de cura**  
definido pelo fabricante /  
Follow curing time defined by  
the manufacturer /  
Siga el tiempo de curado  
definido por el fabricante

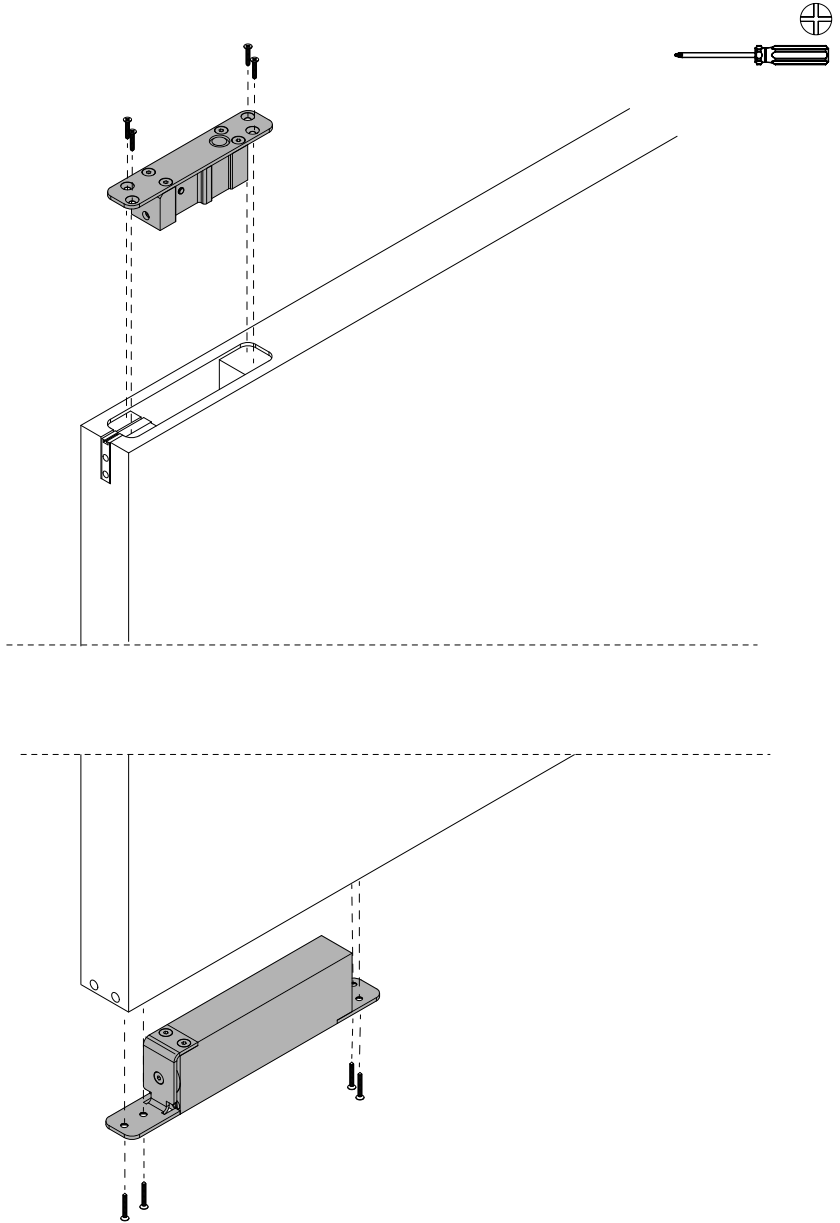

**Rodar 90° de acordo com o lado da montagem**

Rotate 90° according to the mounting side

Girar 90° según el lado de montaje.

**Se for instalada com eixo na posição errada, a porta não fecha correctamente e fará força no sentido errado.**

If installed with the axis in the wrong position, the door will not close correctly and will force in the wrong direction.

Si se instala con el eje en la posición incorrecta, la puerta no cerrará correctamente y forzará en la dirección incorrecta.

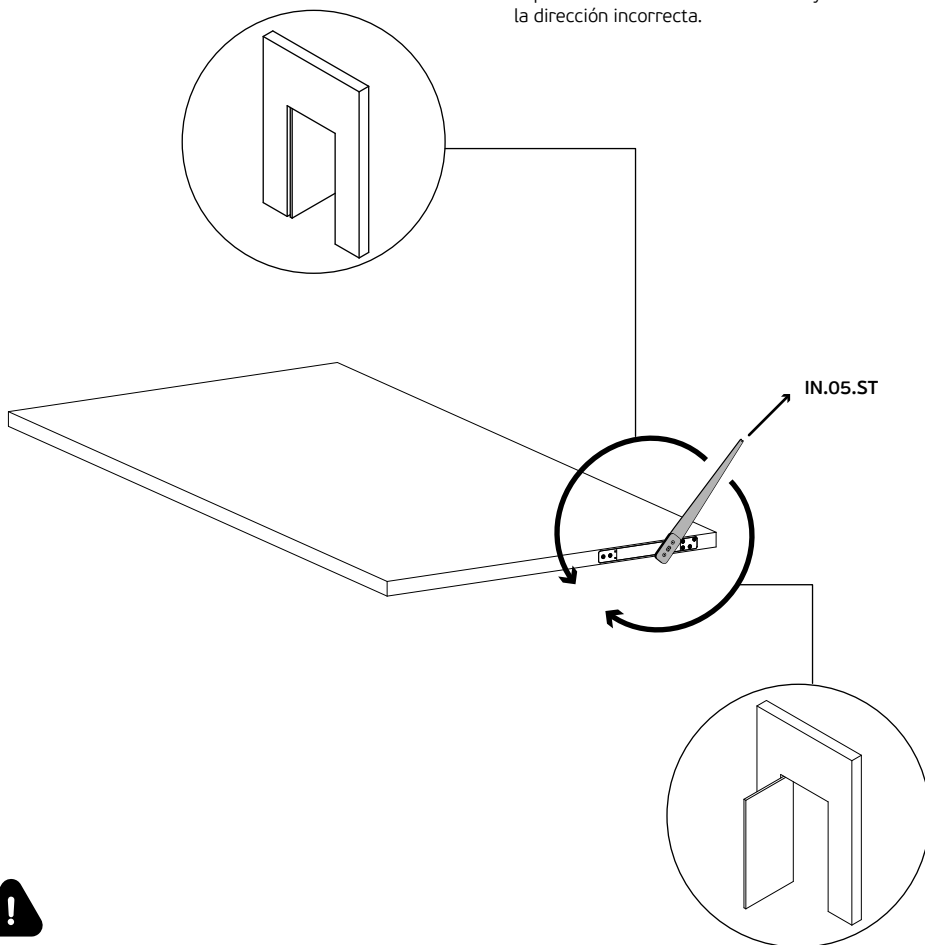

**Risco de danificar se for instalada com eixo na posição errada.**

Risk of damage if installed with the axle in the wrong position

Riesgo de daños si se instala con ele eje na posición errada.

6

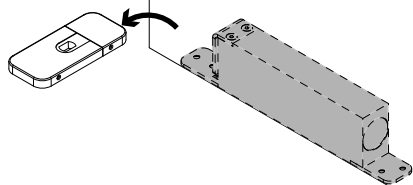

7

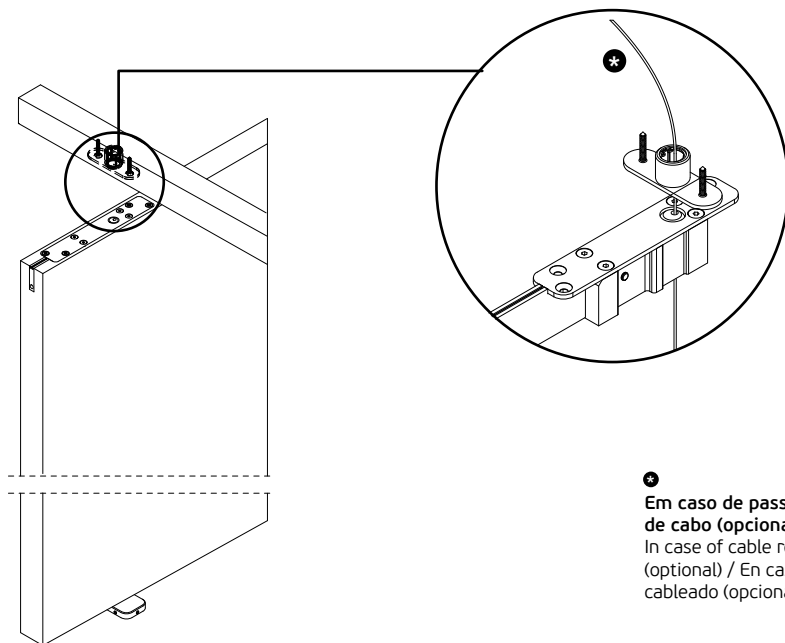

★  
Em caso de passagem  
de cabo (opcional) /  
In case of cable routing  
(optional) / En caso de  
cableado (opcional) /

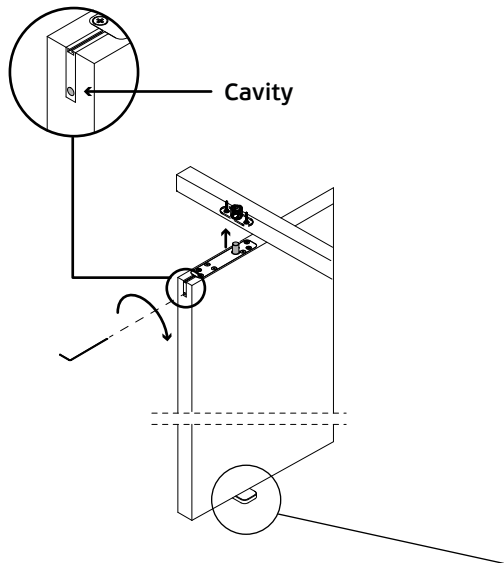

4

**IN.05.213.5**  
**Chave especial /**  
**Special key /**  
**Llave especial**

**BH3**

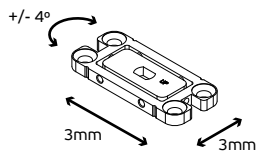

**BH1**

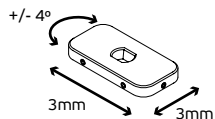

**AVISO - RISCO DE MAU FUNCIONAMENTO!**  
**WARNING - RISK OF MALFUNCTION!**  
**ADVERTENCIA - ¡RIESGO DE MAL FUNCIONAMIENTO!**

**OS EIXOS DEVEM ESTAR CENTRADOS.**  
**THE AXLES MUST BE CENTERED.**  
**LOS EJES DEBEN ESTAR CENTRADOS.**

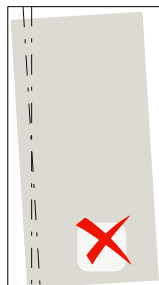
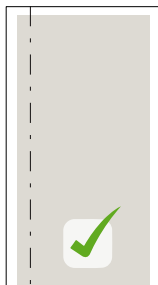

### BH3



Chave allen 3mm /  
Allen key 3mm /  
Llave allen 3mm

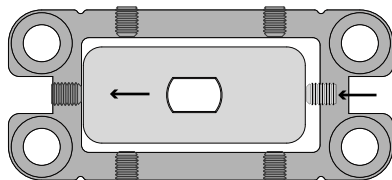
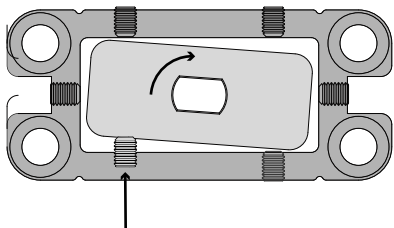

**No ajuste da posição da porta, o sentido do movimento é igual ao sentido do parafuso.**

When adjusting the door position, the direction of movement is the same as the direction of the screw.

Al ajustar la posición de la puerta, la dirección del movimiento es la misma que la del tornillo.

### BH1

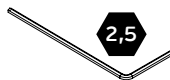

Chave allen 2,5mm /  
Allen key 2,5mm /  
Llave allen 2,5mm

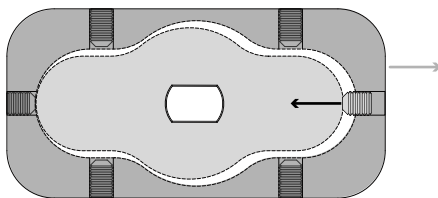
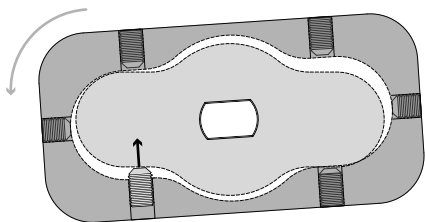

**No ajuste da posição da porta, o sentido do movimento é oposto ao sentido do parafuso.**

When adjusting the door position, the direction of movement is opposite to the direction of the screw.

Al ajustar la posición de la puerta, la dirección del movimiento es opuesta a la dirección del tornillo.

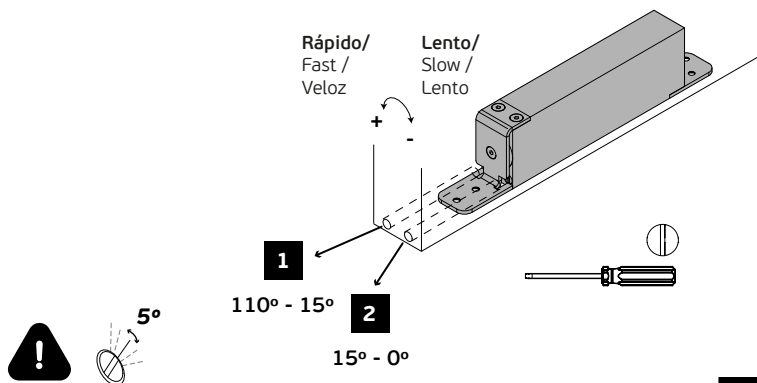

**AVISO - RISCO DE DANOS!**  
**WARNING - RISK OF DAMAGE!**  
**ADVERTENCIA - ¡RIESGO DE DAÑOS!**

**Não force ao apertar ou desapertar.**  
**Não exceda o ângulo de 5° sem testar.**  
**Faça movimentos suaves ao apertar ou desapertar.**  
**Não force o pivot se a porta não fechar.**

*Do not force when tightening or loosening.*  
*Do not exceed the 5° angle without testing.*  
*Make smooth movements when tightening or loosening.*  
*Do not force the pivot if the door doesn't close.*

*No fuerce al apretar o aflojar.*  
*No exceda el ángulo de 5° sin probar.*  
*Realice movimientos suaves al apretar o aflojar.*  
*No fuerce el pivote si la puerta no cierra.*

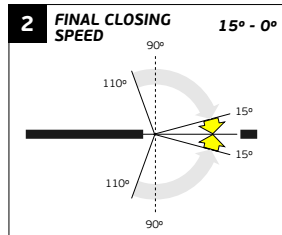
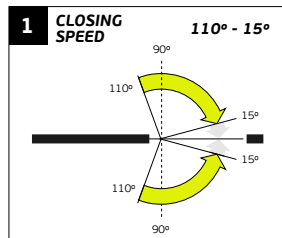

**Acessórios opcionais / Optional accessories / Accesorios opcionales**

**IN.17.012**

**Retentor magnético. Material: Neodímio (Preto) /**  
**Magnetic retainer. Material: Neodymium (Black) /**  
**Retenedor magnetico. Material: Neodímio (Negro)**



**Acessório opcional para auxiliar a retenção nos 0° em caso de variações de pressão elevadas.**  
**Optional accessory to assist retention at 0° in case of high pressure variations.**  
**Accesorio opcional para ayudar a la retención a 0° em caso de variaciones elevadas de presión.**

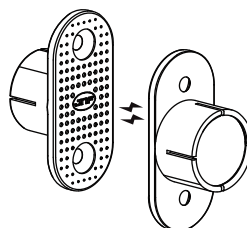

Pode ser necessário reajustar as válvulas após os primeiros 5.000 ciclos.

It may be necessary to readjust the valves after the first 5.000 cycles.

Puede que sea necesario reajustar las válvulas después de los primeros 5.000 ciclos.

**Checklist Manutenção Anual /**

**Annual Maintenance Checklist / Lista de verificación de mantenimiento anual**

<b>Etapa /Data</b> Stage / Date Etapa / Fecha	_____ _ / _ / ____	_____ _ / _ / ____	_____ _ / _ / ____	_____ _ / _ / ____
<b>Verificação da velocidade de fecho /</b> Closing speed check / Control de ajuste de velocidad de cierre				
<b>Lubrificação do eixo superior com spray de massa consistente /</b> Lubrication of the upper axle with grease spray / Lubricación del eje superior con spray de grasa				
<b>Verificação do aperto da base /</b> Checking the base tightness / Comprobación de la estanqueidad de la base				
<b>Verificação da posição do eixo superior /</b> Checking the upper axle position / Comprobación de la posición del eje superior				
<b>Verificação de folgas /</b> Checking clearances / Comprobación de holguras				



---

**J. Neves & Filhos**  
**Comércio e Indústria de Ferragens, S.A.**

---

Rua das Mimosas, 849/851  
Zona Industrial das Mimosas  
S. Pedro da Cova | Ap. 75  
4424-909 Gondomar PORTUGAL

jnf@jnf.pt | [www.jnfhardware.com](http://www.jnfhardware.com)

---

